

F4 GEOMETRY

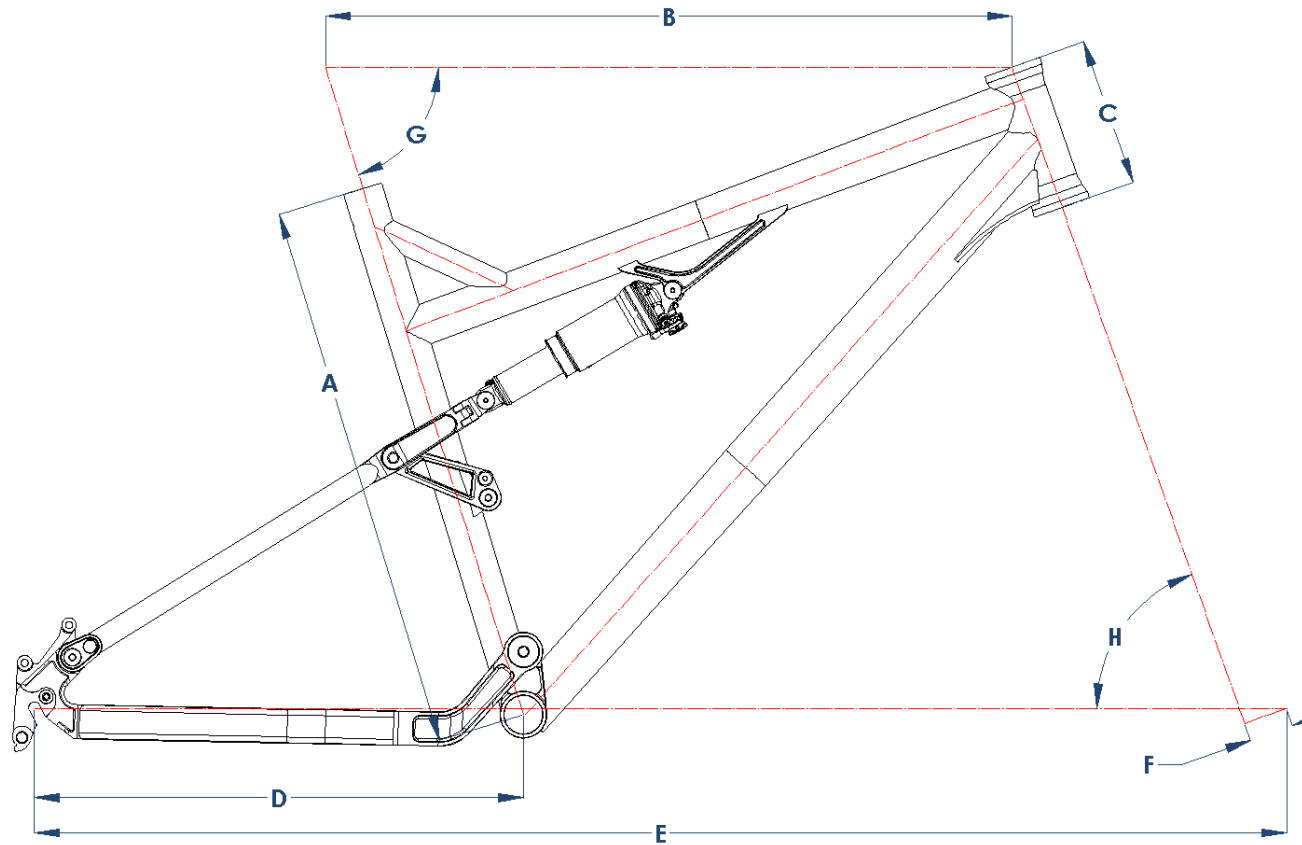

DIMENSION	DESCRIPTION	SML-15"	MED-17"	LRG-19"	XLG-21"
A	Seat Tube	380	430	480	530
B	Effective Top Tube	560	585	600	620
C	Head Tube	100	110	130	160
D	Chain Stay	427	427	427	427
E	Wheel Base	1052	1078	1094	1115
F	Fork Offset	39	39	39	39
G	Seat Angle	73.0°	73.0°	73.0°	73.0°
H	Head Angle	70.5°	70.5°	70.5°	70.5°